

ELEMENTE DE LANT CLASA 4 & CLASA 8 IN CONFORMITATE CU EN 1677-1

CARLIG CU TIJA MODEL 521EN

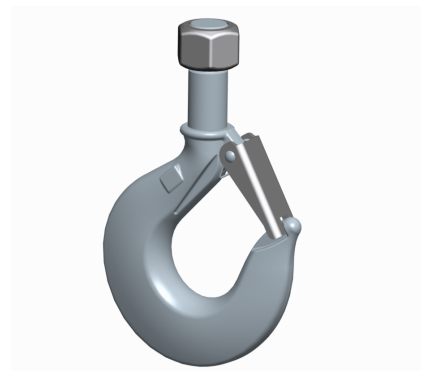
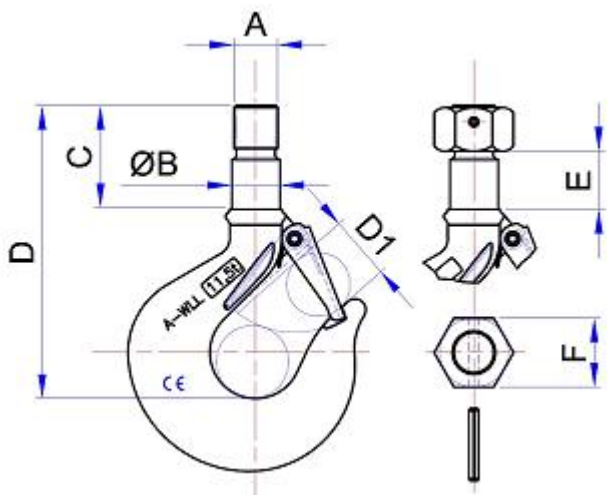

OTEL CARBON CLASA 4 W.L.L. [tone]	OTEL ALIIAT GRAD 8 W.L.L. [tone]	LANT mm	DIMENSIUNI							GREUTATE kg
			A mm	B mm	C mm	D mm	D1 mm	E mm	F mm	
0,8	1,25	6	M12	12	29	88	20	17.5	19	0.30
1	1,6	7	M16	16	42	109	22	25	24	0.48
1,6	2,5	8	M18	18	48	121	23	29	27	0.70
2	3,2	10	M20	20	50	132	27	29	30	1.05
3,2	5,4	13	M24	25	62	163	35	37	36	1.80
5	8	16	M30	30	75	201	43	44.5	46	3.80
7,5	11,5	19	M36x3	40	86	242	53	48.5	55	6.72
10	16	22	M42x3	45	101	268	58	58	65	9.95
15	22	26	M52x3	55	117	327	78	62.5	80	17.60
-	31,5	32	M64x4	65	145	395	87	78	100	33.50

- CLASA 4: Coeficient de siguranta 5
- CLASA 8 : Coeficient de siguranta 4
- Culoare NEGRU NATURAL (sablata)

